

> Unitap™ OxyLok™ Dispenser



Leading the pack in dispensing
solutions worldwide.

TW Fastex™

OxyLok™ Technology Improves Your Operations and Protects Your Product

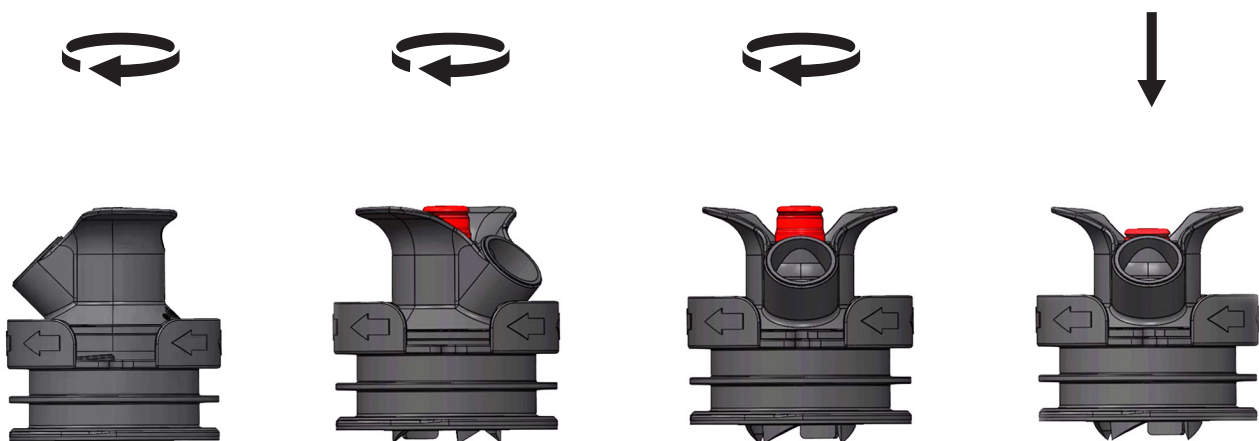

OxyLok technology pierces the bag at first-time use preventing oxygen transfer to the product before initial consumption.

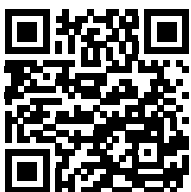

Scan QR code for
Unitap™ OxyLok™
animation.

The Unitap™ OxyLok™ Dispenser designed for external bag attachment, features advanced OxyLok™ technology that pierces the bag at first-time use, thereby eliminating oxygen transfer to the product before its initial consumption.

With precision sealing surfaces and innovative tooth design, the system ensures smooth, low torque rotation, making dispensing effortless and efficient.

With over 25 years of innovation and development in dispensing solutions, ITW Fastex is committed to delivering world-class solutions that ensure the ultimate protection for your product.

Market-leading Performance

The Unitap™ OxyLok™ Dispenser designed for external bag attachment, features advanced OxyLok technology that pierces the bag at first-time use, thereby eliminating oxygen transfer to the product before its initial consumption. OxyLok™ precision sealing surfaces and innovative tooth design, the system enables smooth, low-torque rotation, making dispensing effortless and efficient.



Flow rate (seconds per litre):

17.0 (open container)

23.0 (2 L bag in box)

Tap Dimensions:

Height 46.6mm x Width 43mm x Depth 42 mm

Gravity-fed Functionality

Without the need for pumps or power outlets, using Unitap™ OxyLok™ Dispenser can significantly reduce the cost and footprint of dispensing stations without compromising performance.

Superior Seal - Product Integrity Assurance

Unitap™ OxyLok™ Dispensers are 100% pressure decay tested to ensure the integrity of the seal preventing leaks and loss of product.

User-friendly

Easy to use the Unitap™ OxyLok™ Dispenser is a single-handed operation. The easy turn on/off flow dispenses in a wide range of liquid beverage applications and provides an unobstructed view of the product as it flows.

Single Piece Gland & Tap

The single piece Unitap™ OxyLok™ Dispenser reduces customer inventory and is suitable for use in vertical filling machines which are 2-3x faster than traditional fillers.

Compatible with 1.5L and 3L boxes, the single piece dispenser provides easy installation to bag.

Component Materials

The Unitap™ OxyLok™ Dispenser component materials are high-density polyethylene (HDPE) and polypropylene (PP). (US FDA and EU compliant for food contact. An internal lubricant blend of a USP white petroleum jelly and white oil is applied between the actuator & body.)

*Technical data sheet available on request.

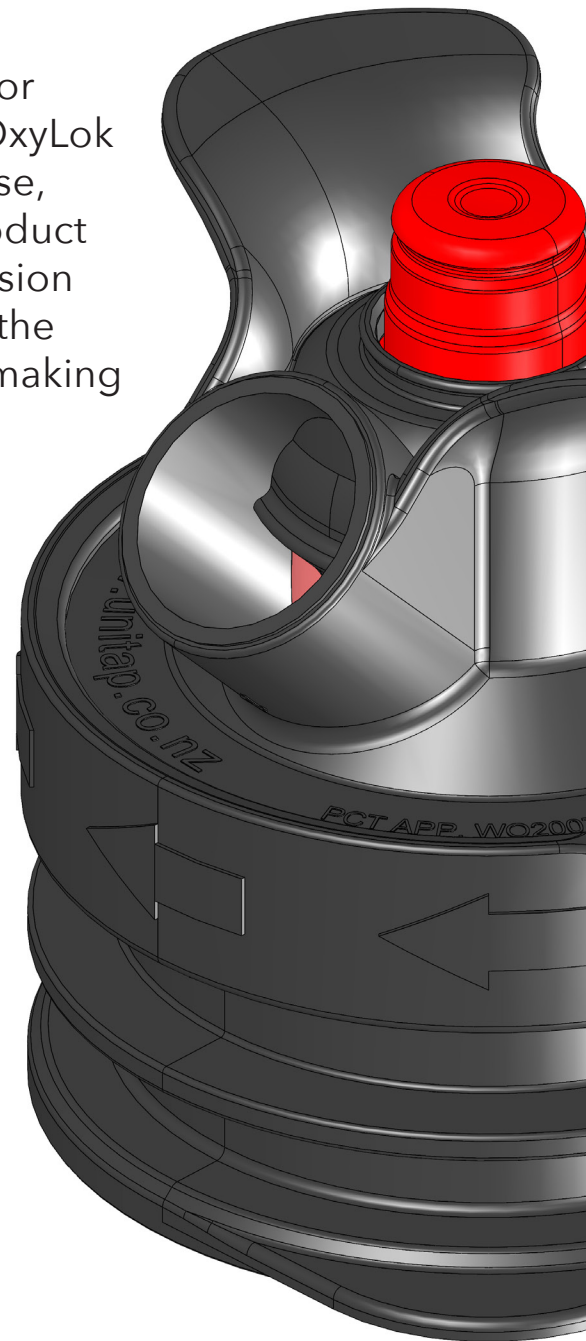

Retail and Household Bag-In-Box Solutions

World class performance and reliability, the Unitap™ OxyLok™ Dispenser is designed to suit the requirements of liquid beverages including premium wine, spirit and wine based cocktails, juices and other non-alcoholic beverages.



Whether on a retail shelf, or for household use, the Unitap Oxylok Dispenser offers users convenient, leak-free dispensing.

Why Choose Flexible Packaging?

Ensuring product integrity, system efficiency and environmental responsibility are essential in packaging, storing and shipping food and beverage products around the world.



With **versatility, durability and efficiency** in conserving resources, flexible packaging provides benefits to both manufacturers and end-users alike.



Less raw material and natural resources used during production.



Less packaging waste with optimized product-to-pack ratio.



Maximized performance due to unrivaled quality design and engineering.



Less energy required during production and transportation.



Less transportation required with more efficient logistics.



Product and company branding opportunities.



Less product waste with excellent shelf-life capabilities.



ITW Fastex is a market leader in the manufacture and supply of a broad range of quality fitments for dispensing solutions worldwide.



ITW Fastex taps, fitments and connectors are world renowned for quality and reliability and with over 30 years' experience, a strong emphasis on quality and a dedicated research and development team, ITW Fastex brings exceptional value to its global customers.

Whatever your dispensing requirements, the ITW Fastex team will work with you to establish a leading-edge solution.

Please contact us to receive a copy of our Taps & Fitments Product Line Book.

ITW Fastex NZ

☎ +64 9 820 2722

✉ info@fastex.com
